



**RIGHT ANGLE
SERVO GEARHEADS**

DYNABOX[®]

DYNABOX® Provides :

- To machine designers a convenient option of turning servomotor drive systems through 90 degrees.

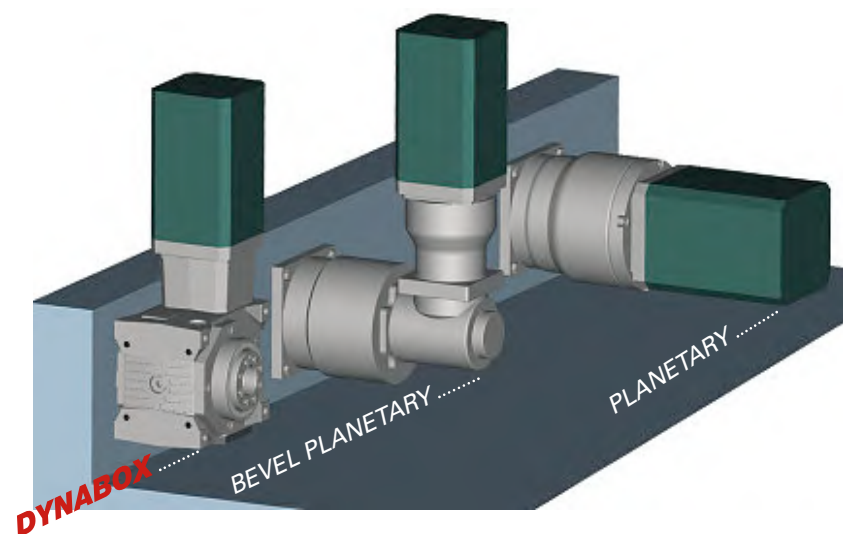

- To OEMs with the ideal solution to reduce costs in servomotor applications by replacing bevel planetary gearheads



- Hollow output with shrink disc (*designer's favorite*), for easy integration



- Robot flange output, for tilting stiffness and compactness



- Solid output (single or dual), a classical solution

TABLE OF CONTENTS

DYNABOX® RIGHT ANGLE SERVO GEARHEADS :

Introduction	4-5
Selection	6
Ratings and technical specifications	7
DYNABOX® with output robot flange	8-9
DYNABOX® with output hollow shaft (smooth with shrink disc or with keyway) ..	10-11
DYNABOX® with output solid shaft (single and double)	12-13
Input servo couplings	14
Input servo flanges	15
"How to order" guide	16

DYNASET HIGH PRECISION GEAR SETS :

Introduction	17
Dimensions	18
Backlash adjustment device for DYNASET	19

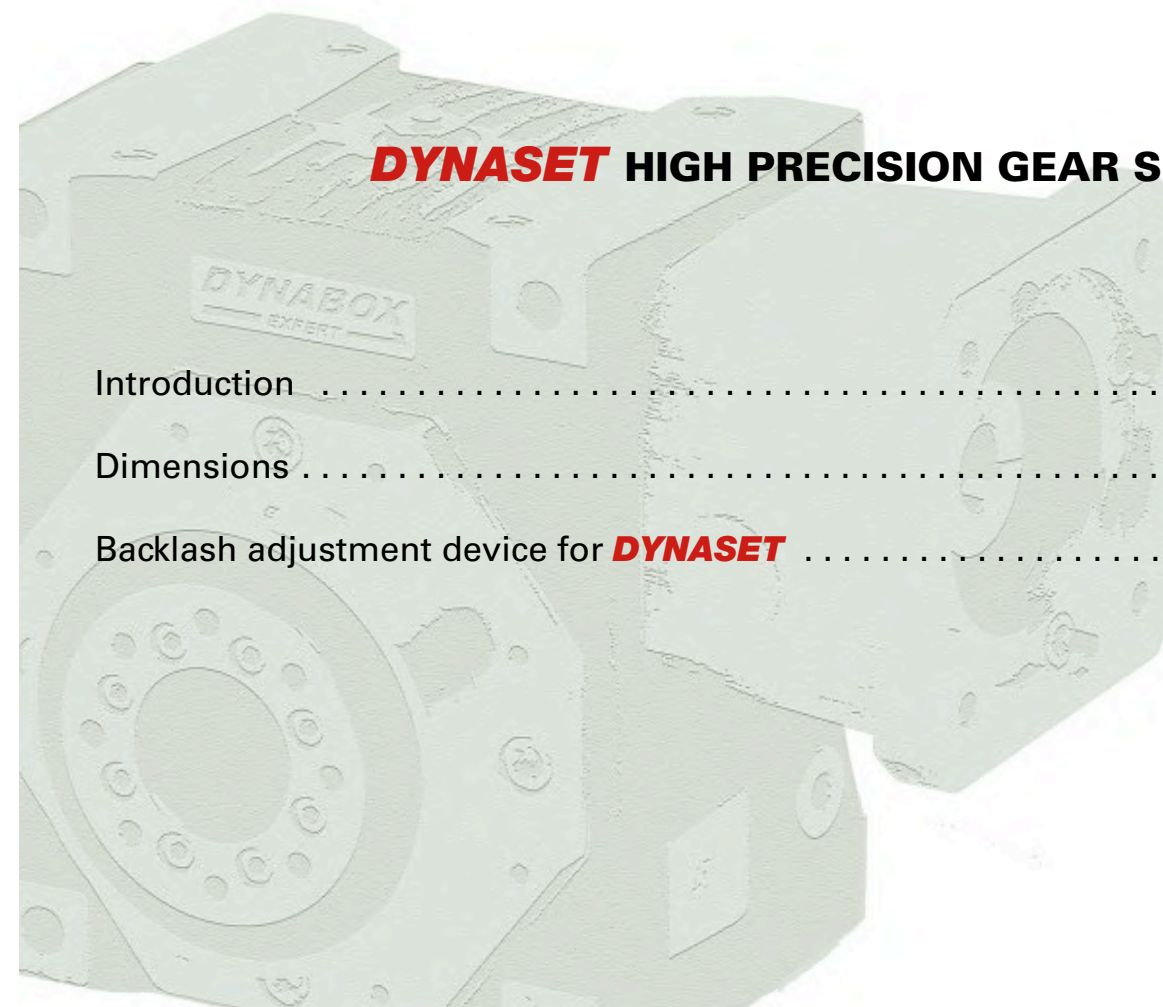

DYNABOX[®] HIGHLIGHTS

Preloaded input taper bearings :

provides higher stiffness.
2 bearings mounted on same side insure constant preload while temperature raises.
It maximizes bearing life.
On the opposite side, an axial-free ball bearing.

Maintenance free :

life-lubricated unit
with high performance
synthetic lubricant

Oversized taper roller bearings,
providing unmatched radial loads

Single piece housing, made of cast and
heat treated aluminium-magnesium alloy.
Offering superior rigidity and low weight

Optimized contact pattern : a unique process to cut gears,
combined to a state of the art assembly lead to a nearly 90%
pattern surface, reducing drastically the contact pressure.



Special bronze alloy : developed by ourselves, it provides an unmatched wear
resistance. Combined with 90% contact pattern, lowest backlash is maintained
throughout the working life of the gearhead.

Thanks to that, **DYNABOX[®]** gearheads can run up to **6000RPM**
Apparently similar products available on the market do not offer such performance

Servomotor mounted within 5 minutes :

a high stiffness below coupling eliminates
shaft alignment problems.
A mating flange to **your** servomotor can
always be supplied from our stock.

Output torsional backlash available in 3 ranges :

EXPERT : 1 arcminute for the most demanding applications

MEDIUM : 5 arcminutes, a good compromise price/quality

BASIC : 10 arcminutes, a budget gearhead to cut servo system costs

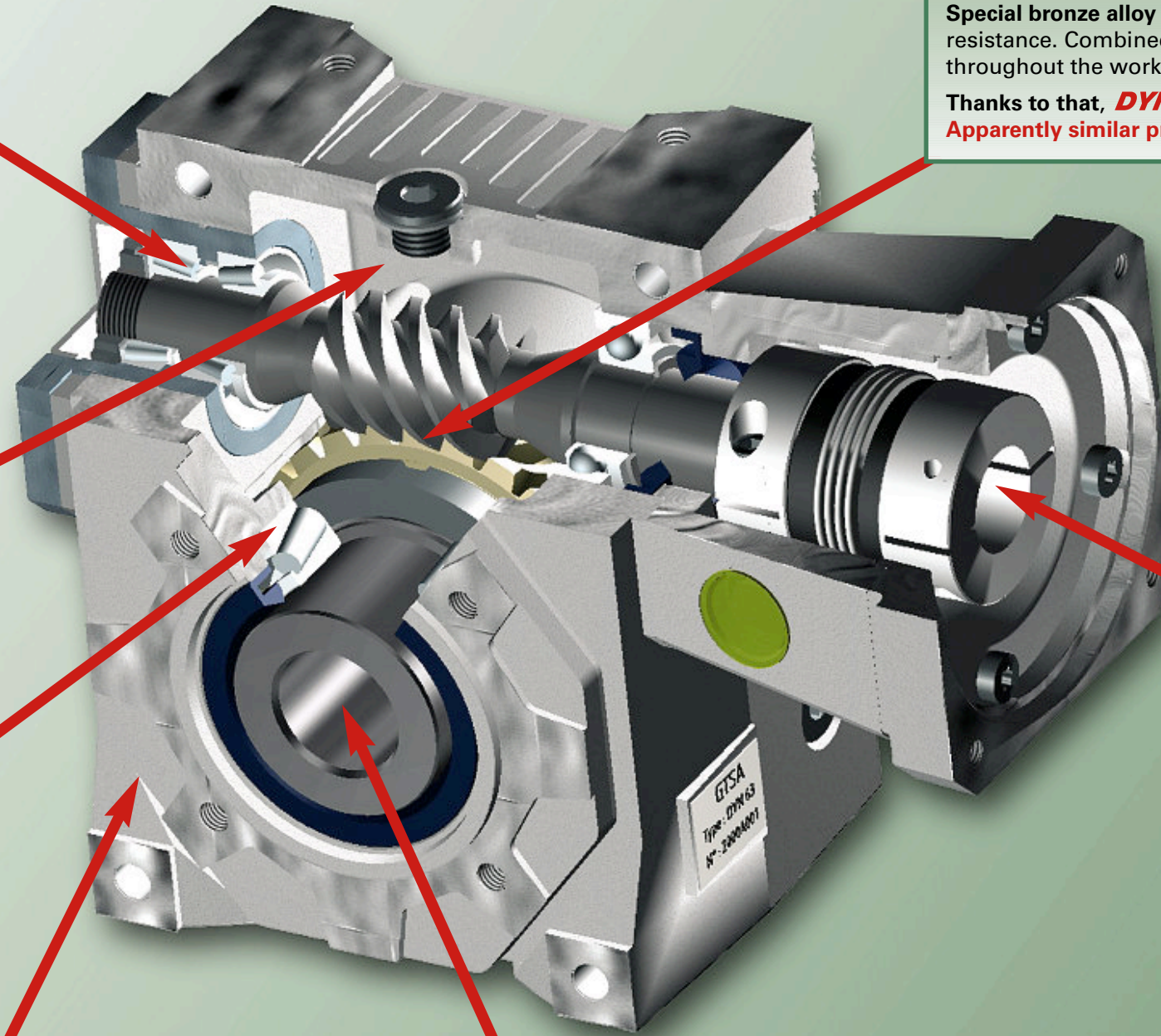

DYNABOX[®] ROBOT FLANGE

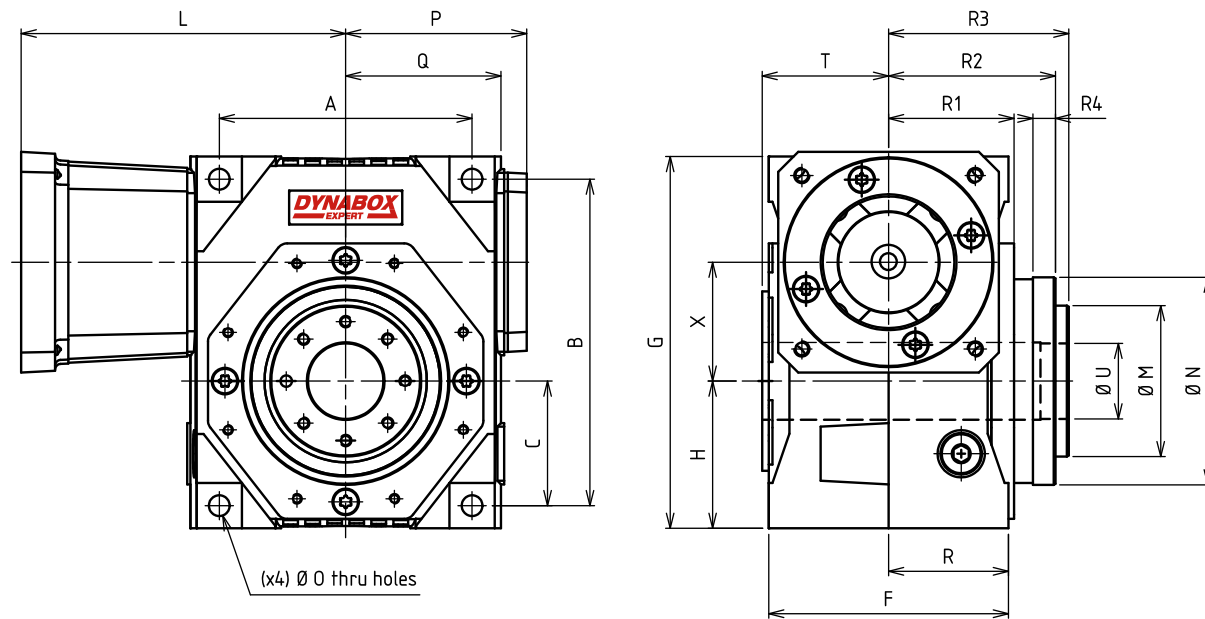

(x4) Ø 0 thru holes

INPUT SHAFT VERSION

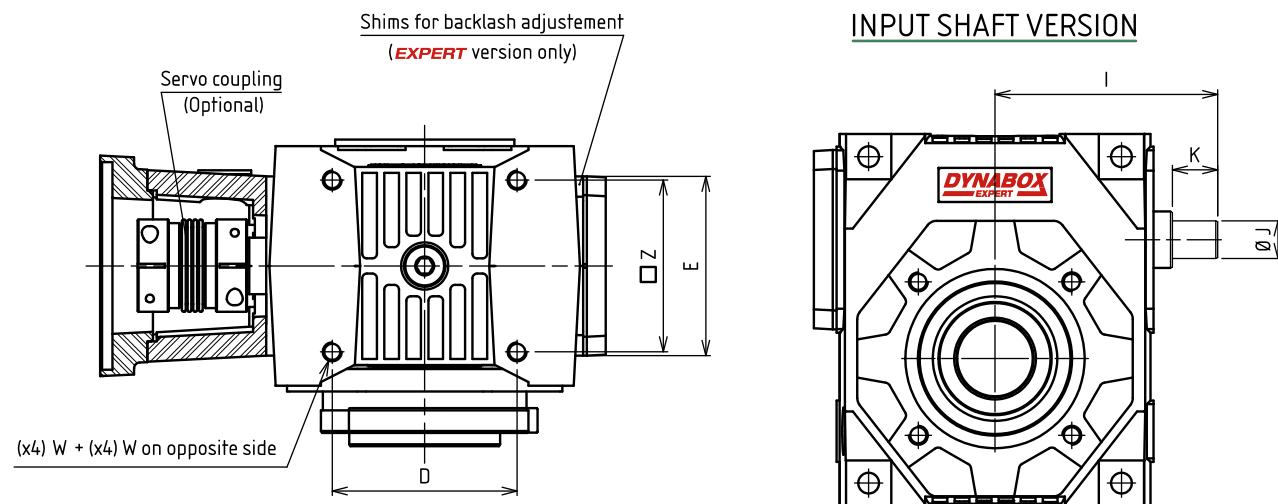

Shims for backlash adjustment
(EXPERT version only)

Servo coupling
(Optional)

(x4) W + (x4) W on opposite side

DYNABOX	45	55	63	75	90	110
A	108	120	134	172	186	220
B	135	155	173	208	234	276
C	53	61	66	82	91	108
D	81	90	98	136	141	175
E	68	78	91	110	130	140
F	100	112	127	148	170	182
G	153	175	197	232	264	306
H	62	71	78	94	106	123
I Maxi	105	116	126	151	165,5	189
I mini	97,5	108	116	140	153,5	177
J (h6)	15	18	20	24	28	32
K	20	22	24	28	28	36
L	see page 15					
M (h7)	50	63	80	100	125	160
N (h7)	80	90	110	140	165	200
O	9	9	11	11	13	13
P (Maxi)	83,5	91	101	124	136,5	152
Q	67,5	75	84	104	114,5	132
R	50	56	63,5	74	85	91
R1	54	59	66,5	79	93	100
R2	74	82	88,5	110	129	140
R3	80	89	95,5	117	138	150
R4	10	12	12	15	18	22
S (H7)	6	6	6	8	8	10
T	53	59,5	67	78	89	96
U (H7)	25	31,5	40	50	63	80
V	M6	M6	M6	M8	M8	M10
V1	40	50	63	80	100	125
V2	7	7	7	11	11	11
W	M8	M8	M10	M10	M12	M12
X	45	55	63	75	90	110
Y	M5	M5	M5	M6	M8	M8
Y1	100	109	135	168	190	233
Y2	8	8	8	12	12	16
Z	75	75	85	95	115	115
WEIGHT (kg)	7,6	10,5	15,2	22,5	36,15	51,7
Max. tilting torque (Nm)	250	450	780	1200	2150	3900
Tilting rigidity (Nm/arcmin)	330	520	580	800	1550	3050

SIZES 45 - 55 and 63

SIZES 75 and 90

SIZE 110

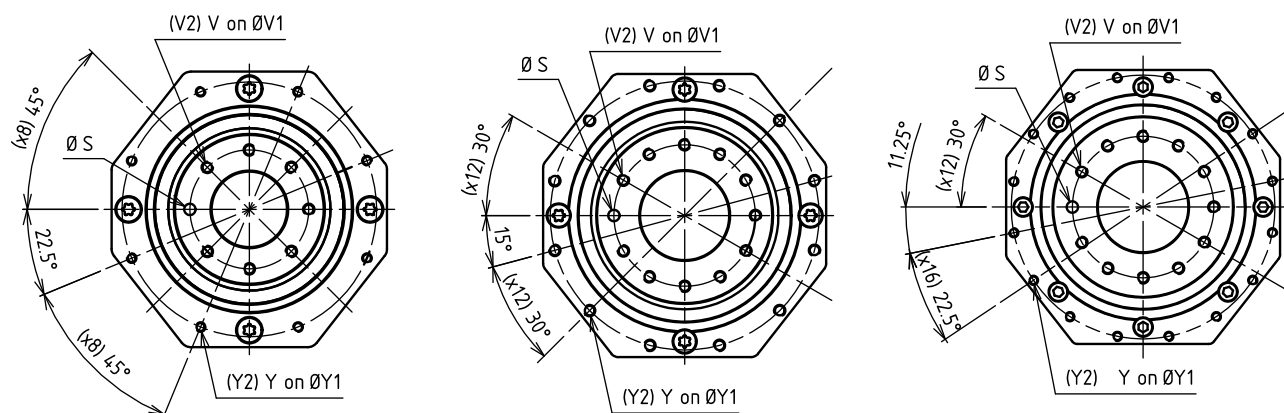

MOUNTING POSITIONS

H1

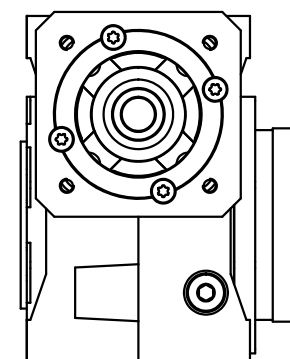

H2

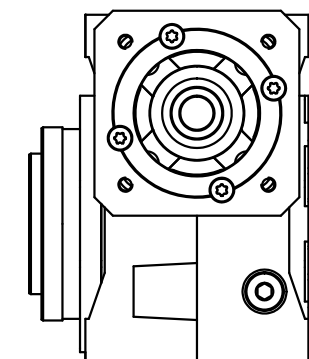

All mounting positions on the machine are accepted with the factory lubricated **DYNABOX**. However, applications which use less than 360° of the output require a higher oil level. It should be specified when ordering.

DYNABOX® HOLLOW SHAFT

GLATTE WELLE FÜR SCHRUMPFSCHEIBENANBAU (AB LAGER VERFÜGBAR)

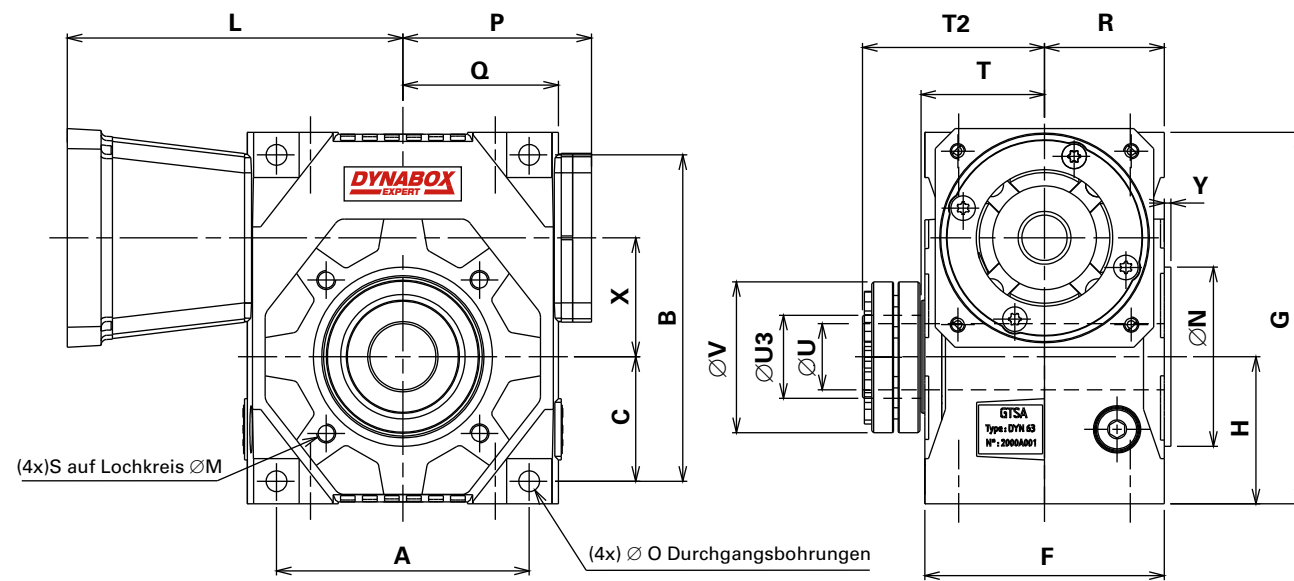

MIT FREIER EINTRIEBSWELLE

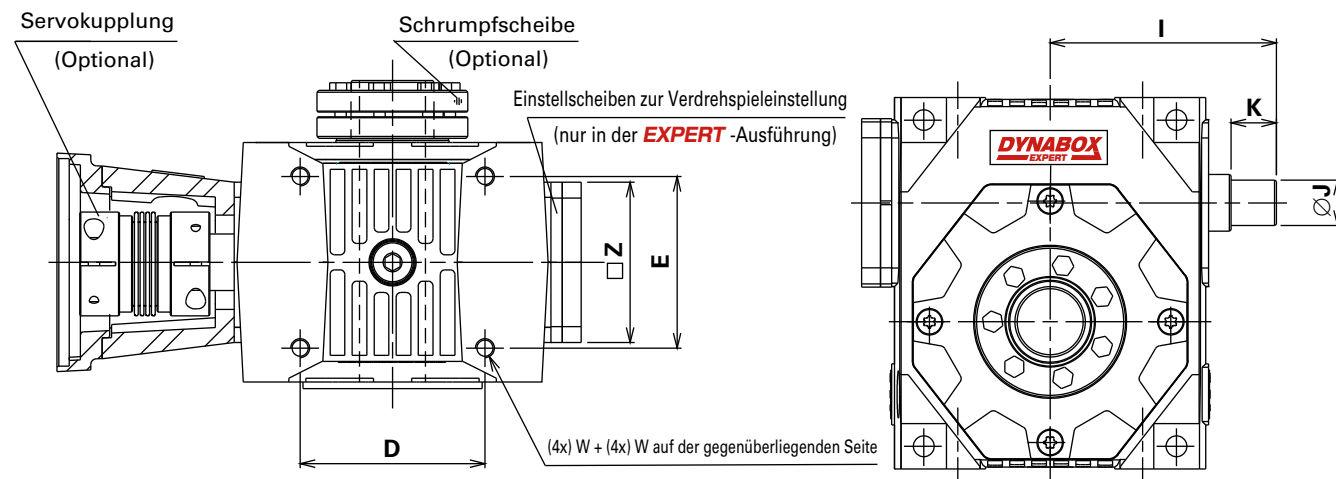

HOHLWELLE MIT PASSFEDER (NICHT LAGERND)

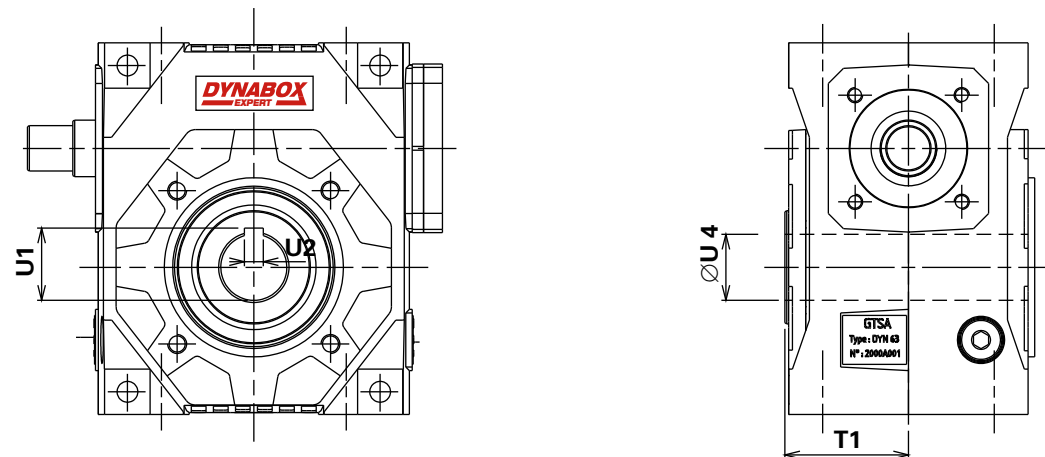

DYNABOX	35	45	55	63	75	90	110
A	86	108	120	134	172	186	220
B	110	135	155	173	208	234	276
C	44,5	53	61	66	82	91	108
D	62	81	90	98	136	141	175
E	56	68	78	91	110	130	140
F	86	100	112	127	148	170	182
G	126	153	175	197	232	264	306
H	52,5	62	71	78	94	106	123
I Maxi	84	105	116	126	151	165,5	189
I mini	77,5	97,5	108	116	140	153,5	177
J (h6)	12	15	18	20	24	28	32
K	17	20	22	24	28	28	36
L	see page 15						
M	65	85	100	115	130	165	200
N (j7)	50	70	80	95	110	130	165
O	7	9	9	11	11	13	13
P (Maxi)	70	83,5	91	101	124	136,5	152
Q	55	67,5	75	84	104	114,5	132
R	43	50	56	63,5	74	85	91
S	M6	M8	M8	M10	M10	M12	M12 (x8)
T	45	52	58	65,5	76	87	93
T1	45	52	58	65,5	76	87	93
T2	69	78	87	96,5	110	124	133
U (H7)	20	25	30	35	40	50	60
U1	18,3	28,3	33,3	38,3	43,3	53,8	64,4
U2	5	8	8	10	12	14	18
U3	24	30	36	44	50	68	80
U4	16	25	30	35	40	50	60
V	50	60	72	80	90	115	145
W	M6	M8	M8	M10	M10	M12	M12
X	35	45	55	63	75	90	110
Y	3	3	3,5	3,5	4	4	5
Z	58	75	75	85	95	115	115
WEIGHT (kg)	3,4	6,2	8,5	13,9	20,5	32,5	46,5

MOUNTING POSITIONS

H1

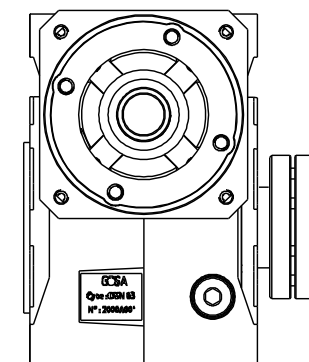

H2

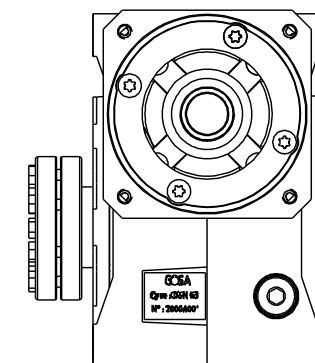

All mounting positions on the machine are accepted with the factory lubricated **DYNABOX**. However, applications which use less than 360° of the output require a higher oil level. It should be specified when ordering.

DYNABOX[®] OUTPUT SHAFT

SINGLE OUTPUT SHAFT

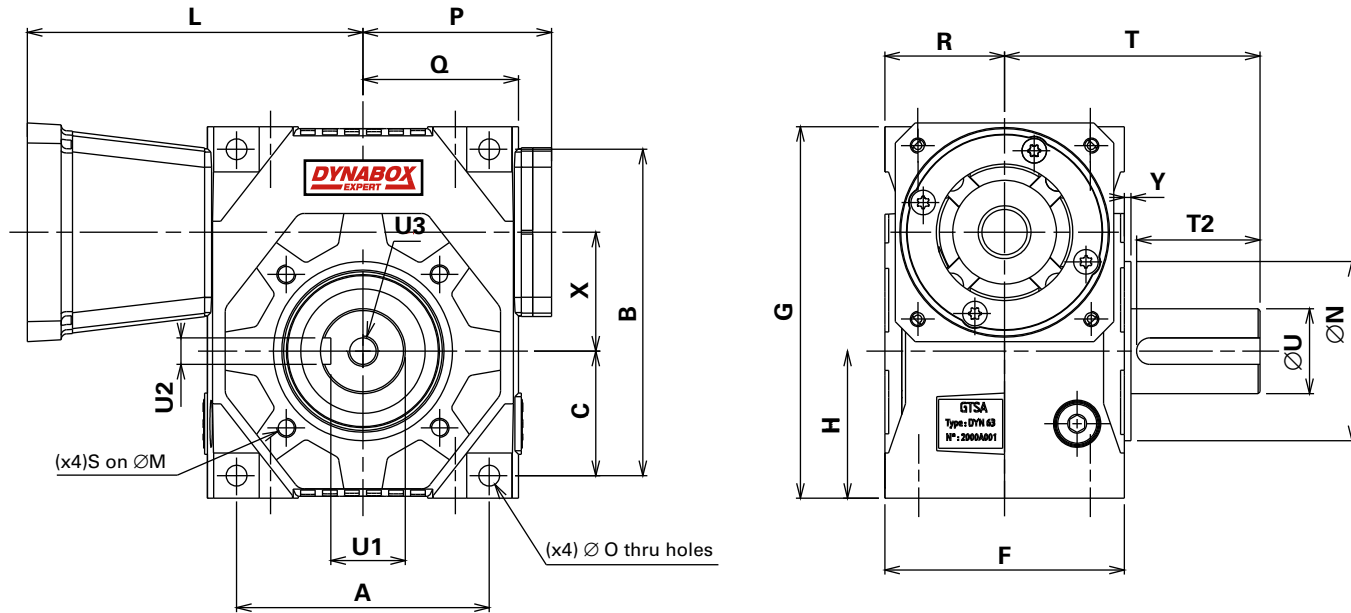

INPUT SHAFT VERSION

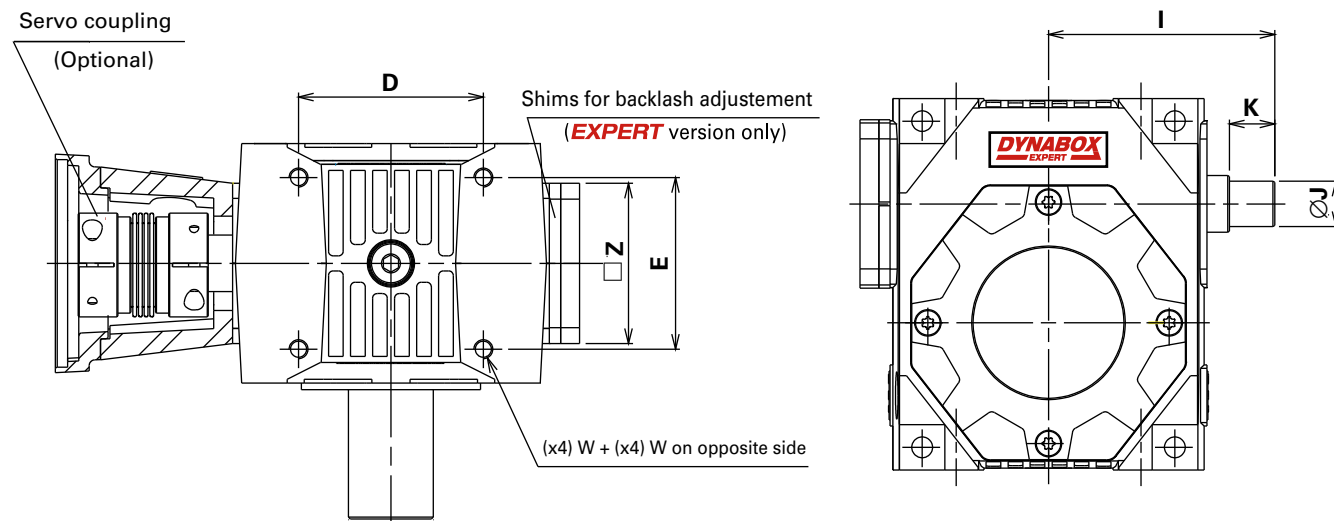

DUAL OUTPUT SHAFT

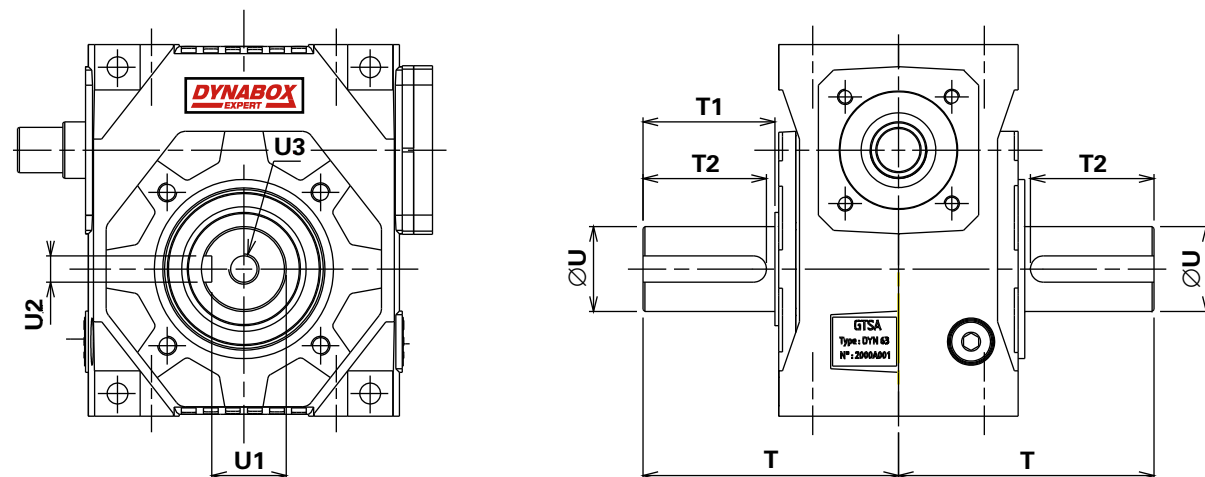

DYNABOX	35	45	55	63	75	90	110
A	86	108	120	134	172	186	220
B	110	135	155	173	208	234	276
C	44,5	53	61	66	82	91	108
D	62	81	90	98	136	141	175
E	56	68	78	91	110	130	140
F	86	100	112	127	148	170	182
G	126	153	175	197	232	264	306
H	52,5	62	71	78	94	106	123
I Maxi	84	105	116	126	151	168,5	189
I mini	77,5	97,5	108	116	140	153,5	177
J (h6)	12	15	18	20	24	28	32
K	17	20	22	24	28	28	36
L					see page 15		
M	65	85	100	115	130	165	200
N (j7)	50	70	80	95	110	130	165
O	7	9	9	11	11	13	13
P (Maxi)	70	83,5	91	101	124	136,5	152
Q	55	67,5	75	84	104	114,5	132
R	43	50	56	63,5	74	85	91
S	M6	M8	M8	M10	M10	M12	M12 (x8)
T	83	107	118	135,5	151	187	208
T1	38(*)	55(*)	60(*)	70	75	100	115
T2	35	50	55	65	70	95,5	110
U (h6)	25	35	40	45	50	65	75
U1	21	30	35	39,5	44,5	58	67,5
U2	8	10	12	14	14	18	20
U3	M10	M12	M16	M16	M16	M20	M20
W	M6	M8	M8	M10	M10	M12	M12
X	35	45	55	63	75	90	110
Y	3	3	3,5	3,5	4	4	5
Z	58	75	75	85	95	115	115
WEIGHT (kg)	3,6	6,8	9,2	15,2	22,2	35,1	50,3

(*) : No shoulder on shaft

MOUNTING POSITIONS

H1

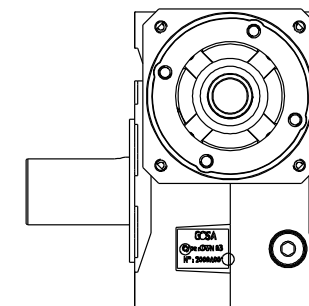

H2

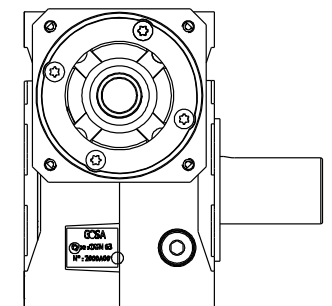

All mounting positions on the machine are accepted with the factory lubricated **DYNABOX**. However, applications which use less than 360° of the output require a higher oil level. It should be specified when ordering.

CONNECTING KIT **DYNABOX**® -SERVOMOTOR

TORSION STIFF COUPLINGS

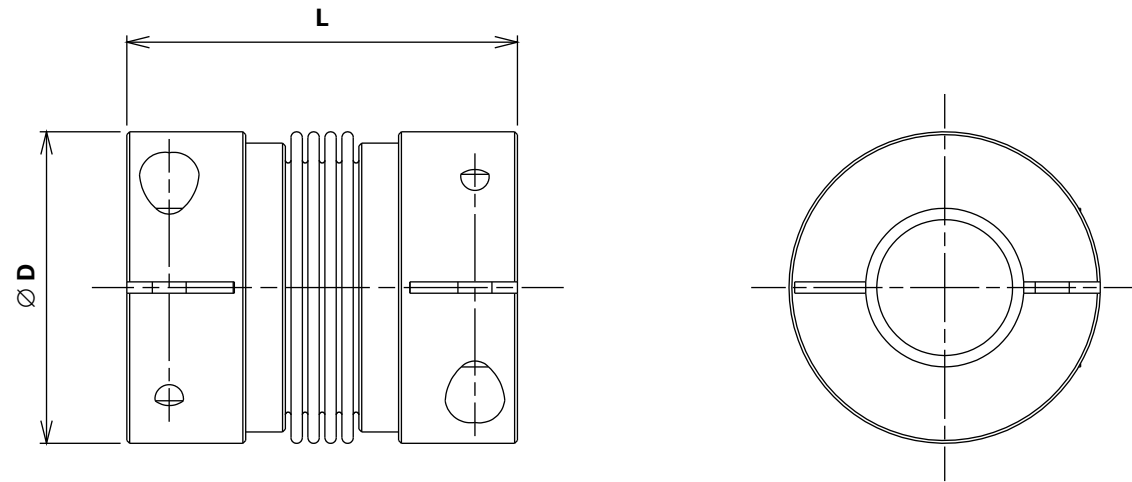

Coupling reference		AM N° 5	AM N° 10	AM N° 15	AM N° 30	AM N° 60	AM N° 80
Ø servo shaft and DYNABOX shaft	mm	<Ø16	<Ø24	<Ø28	<Ø32	<Ø35	<Ø42
Servo nominal torque	Nm	5	10	15	30	60	80
Servo peak torque	Nm	7,5	15	22,5	45	90	120
Ø D	mm	32	40	49	55	66	82
L	mm	42	46	60	70	81	94
Polar moment of inertia	10 ⁻³ kgm ²	0,01	0,02	0,05	0,09	0,18	0,54
Torsional stiffness	Nm/arcmin	2	2,6	6	11	22	37
Tightening torque of campling screws	Nm	4	4,5	9	14	35	70

Specify the coupling reference and the servo shaft Ø when ordering.

Exemple : AM n° 15 Ø 14.

To calculate the input total inertia, add the coupling iner-

CONNECTING FLANGE

Select the required flange on page 15.

If no flange can be found in the list, supply the dimensions from A to Z, or supply the servo reference when ordering.

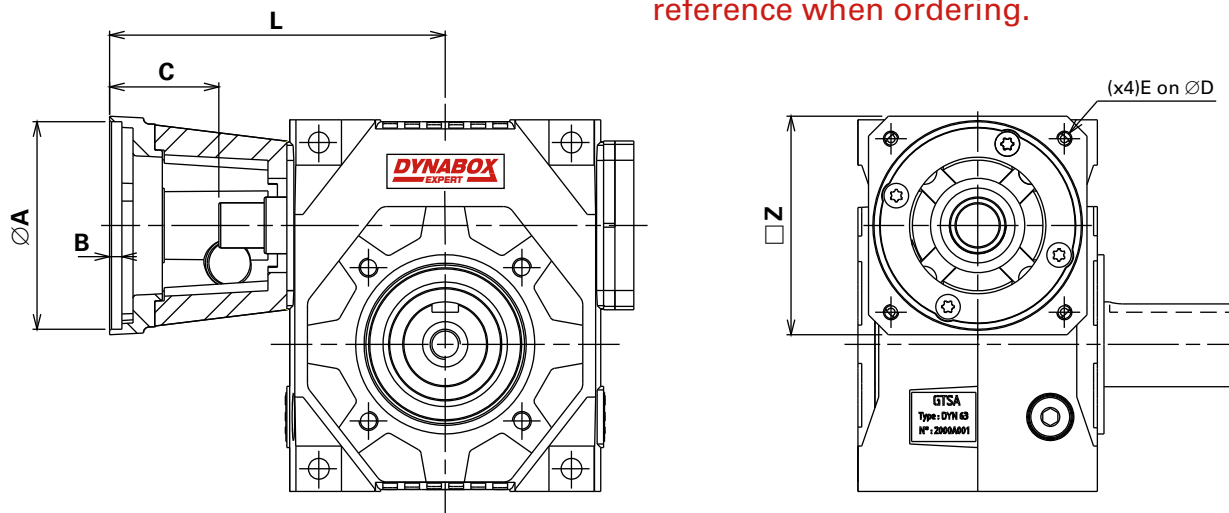

DYNABOX	Reference	A	B	C*	D	E	L	Z
35	BM-F63/40	40	4	32	63	M4	111	65
	BM-F70/50	50	4	35	70	M4	114	65
	BM-F75/60	60	4	35	75	M5	114	65
	BM-F90/70	70	4	45	90	M5	124	90
	BM-F95/50	50	4	35	95	M6	114	90
	BM-F100/80	80	5	45	100	M6	124	90
	BM-F115/95	95	5	45	115	M8	124	118
	BM-F130/95	95	5	55	130	M8	134	118
	BM-F130/110	110	5	55	130	M8	134	118
	BM-F145/110	110	6,5	65	145	M8	144	118
45	BM-F70/50	50	4	35	70	M4	135	81
	BM-F75/60	60	4	35	75	M5	135	81
	BM-F90/70	70	4	45	90	M5	145	91
	BM-F95/50	50	4	35	95	M6	135	91
	BM-F100/80	80	5	45	100	M6	145	91
	BM-F115/95	95	5	45	115	M8	145	115
	BM-F130/95	95	5	55	130	M8	155	115
	BM-F130/110	110	5	55	130	M8	155	115
	BM-F145/110	110	6,5	65	145	M8	165	140
	BM-F165/110	110	6,5	65	165	M10	155	140
BM-F165/130	130	6,5	65	165	M10	155	140	
55	BM-F70/50	50	4	35	70	M4	146	81
	BM-F75/60	60	4	35	75	M5	146	81
	BM-F90/70	70	4	45	90	M5	156	91
	BM-F95/50	50	4	35	95	M6	146	91
	BM-F100/80	80	5	45	100	M6	156	91
	BM-F115/95	95	5	45	115	M8	156	115
	BM-F130/95	95	5	55	130	M8	166	115
	BM-F130/110	110	5	55	130	M8	166	115
	BM-F145/110	110	6,5	65	145	M8	176	140
	BM-F165/110	110	6,5	65	165	M10	166	140
BM-F165/130	130	6,5	65	165	M10	166	140	
63	BM-F70/50	50	4	40	70	M4	160	102
	BM-F75/60	60	4	40	75	M5	160	102
	BM-F90/70	70	4	46	90	M5	166	102
	BM-F100/80	80	5	46	100	M6	166	102
	BM-F115/95	95	5	46	115	M8	166	115
	BM-F130/95	95	5	56	130	M8	176	115
	BM-F130/110	110	5	56	130	M8	176	115
	BM-F145/110	110	6,5	66	145	M8	186	140
	BM-F165/110	110	6,5	66	165	M10	176	140
	BM-F165/130	130	6,5	66	165	M10	176	140
BM-F200/114,3	114,3	6,5	86	200	M10	206	185	
BM-F215/130	130	6,5	66	215	M12	186	185	
BM-F215/180	180	6,5	66	215	M12	186	185	
75	BM-F70/50	50	4	40	70	M4	185	102
	BM-F75/60	60	4	40	75	M5	185	102
	BM-F90/70	70	4	46	90	M5	191	102
	BM-F100/80	80	5	46	100	M6	191	102
	BM-F115/95	95	5	46	115	M8	191	115
	BM-F130/95	95	5	56	130	M8	201	115
	BM-F130/110	110	5	56	130	M8	201	115
	BM-F145/110	110	6,5	66	145	M8	211	140
	BM-F165/110	110	6,5	66	165	M10	201	140
	BM-F165/130	130	6,5	66	165	M10	201	140
BM-F200/114,3	114,3	6,5	86	200	M10	231	185	
BM-F215/130	130	6,5	66	215	M12	211	185	
BM-F215/180	180	6,5	66	215	M12	211	185	
90	BM-F100/80	80	4	46	100	M6	205,5	123
	BM-F115/95	95	5	46	115	M8	205,5	123
	BM-F130/95	95	5	56	130	M8	215,5	123
	BM-F130/110	110	5	56	130	M8	215,5	123
	BM-F145/110	110	6,5	66	145	M8	225,5	140
	BM-F165/110	110	6,5	66	165	M10	215,5	140
	BM-F165/130	130	6,5	66	165	M10	215,5	140
	BM-F200/114,3	114,3	6,5	86	200	M10	245,5	185
	BM-F215/130	130	6,5	66	215	M12	225,5	185
	BM-F215/180	180	6,5	66	215	M12	225,5	185
110	BM-F300/250	250	6,5	88	300	M14	247,5	260
	BM-F100/80	80	4	46	100	M6	229	123
	BM-F115/95	95	5	46	115	M8	229	123
	BM-F130/95	95	5	56	130	M8	239	123
	BM-F130/110	110	5	56	130	M8	239	123
	BM-F145/110	110	6,5	66	145	M8	249	140
	BM-F165/110	110	6,5	66	165	M10	239	140
	BM-F165/130	130	6,5	66	165	M10	239	140
	BM-F200/114,3	114,3	6,5	86	200	M10	269	185
	BM-F215/130	130	6,5	66	215	M12	249	185
BM-F215/180	180	6,5	66	215	M12	249	185	
BM-F300/250	250	6,5	88	300	M14	271	260	

* A spacer can be supplied if motor shaft length is longer than C dimension (specify it when ordering)

HOW TO ORDER

Use following codification to order your **DYNABOX**.

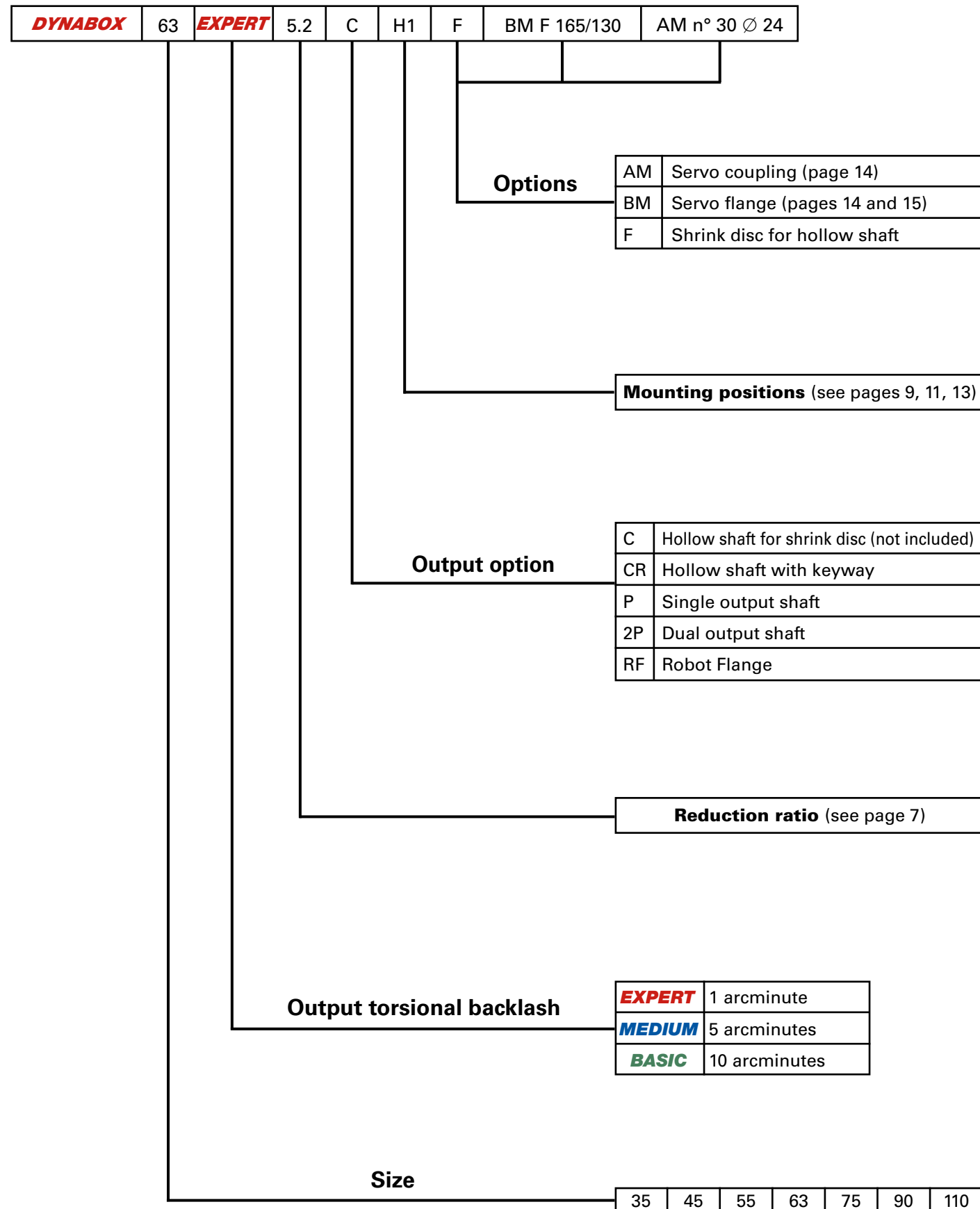

SERVO GEARSETS **DYNASET** WITH ADJUSTABLE BACKLASH

When **DYNABOX** servo gearheads cannot be used, the **DYNASET** servo gearsets, to be mounted in customed housing, are an interesting alternative.

Their performance are comparable to complete reducers, assuming following recommendations :

MOUNTING

Wormshaft : housing and bearing design should allow an axial shifting, necessary for backlash adjustment. The total adjustment range is obtained with a permissible displacement equal to W, as per page 18.

It is recommended, whenever possible, to use our backlash adjustment device, which is delivered preset (see page 19).

The front ball bearing (see page 19) must be engaged on the shaft after the complete gear assembly, and before the backlash adjustment operation.

Wheel ring : Arrows shown on wormshaft and wheel ring must be lined up during assembly (see page 18). As the bore ØA tolerance is H6, it is recommended to grind the shaft with a tolerance k5. This will eliminate any runnout between the wheel ring and the shaft. In order to facilitate the connection between the 2 parts, heat the wheel ring up to 50°C.

After cooling, check that the wheel ring is no buckled, by applying a dial indicator on its face, while rotating the shaft.

Then, finish the pins bores ((xY) ØS, see page 18) of the 2 assembled parts, as they are delivered pre-bored only. Otherwise, screws can be also used.

It is recommended to use taper roller bearings on output shaft, in order to allow an axial displacement of the wheel, during the mounting operations, to center the gear correctly. The contact pattern can be checked with Prussian blue or any similar product. A good pattern should be located slightly on the right side of the wheel tooth flanks (on both sides). It is normal to have no contact on the left side of the flanks. This gap is necessary for a good oil film forming. See sketch below.

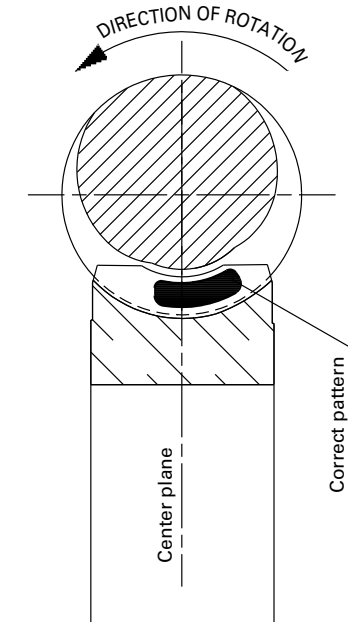

LUBRICATION

The best gear performances in terms of efficiency, life, temperature, will be achieved with a polyglycol lubricant such as MOBIL GLYGOYLE 30 or equivalent. The ratings shown on page 7 can be considered only if this kind of

lubricant is used.

Before use, check that the inner paint of the housing is compatible (Epoxy paints can be used).

Otherwise, use MOBIL SHC 634 or equivalent.

BACKLASH ADJUSTMENT

The accuracy of our servo gearsets **DYNASET** allows them to be set to less than 1 arcminute of backlash, without any efficiency or torque capacity losses (it is assumed than custom machined parts and mounting are correct).

If our backlash adjustment device is used, simply remove some shims (delivered) between the bearing bush and

the housing, until the desired backlash value is obtained. For high speed applications, a backlash between 0,5 to 1 arcminute is recommended.

For very intermittent applications (rotary tables or milling heads of CNC machines for ex.), a backlash down to zero is tolerated, as soon as the no load input torque does not vary more than ± 30 % around the average value.

SERVO GEARSET *DYNASET*

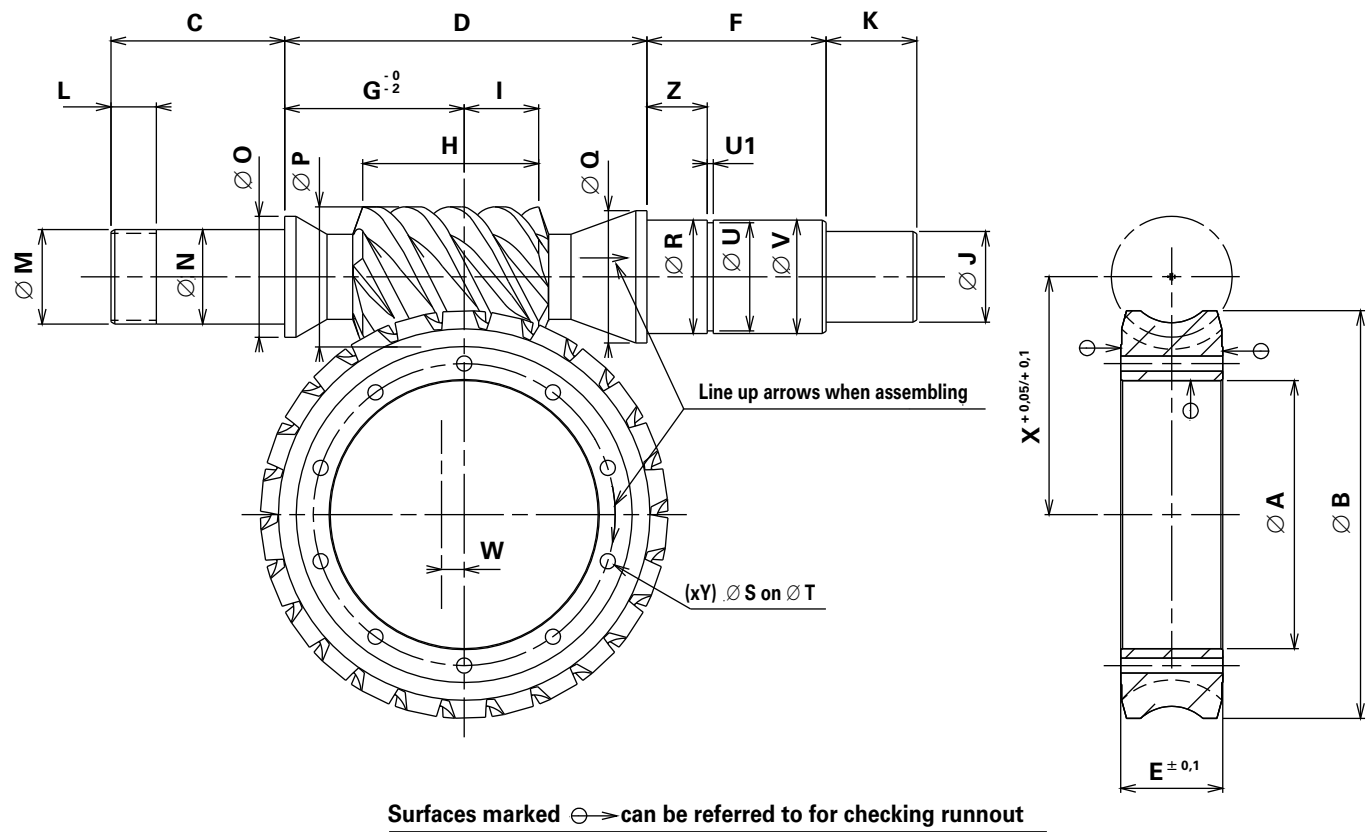

<i>DYNASET</i>	35	45	55	63	75	90	110
A (H6)	32	47	52	71	82	103	136
B Maxi	55	78	92	108	124,5	157,4	191,4
C	33	38	43	46	52	57	60
D	63,5	80	85	97	126,5	144	173
E	14	19	28	27	32	38	40
F	30,5	40	46	46,5	53,5	57,5	56
G	32	40	42	47,5	63	70	82
H Maxi	31	37,6	43,7	49,7	54,7	67,5	75,5
I Maxi	13,5	17,3	20,5	23,4	26,3	33,2	36,1
J (h6)	12	15	18	20	24	28	32
K	17	20	22	24	28	28	36
L	8	9	10	11	13	14	15
M	M15 x 1,00	M17 x 1,00	M20 x 1,00	M25 x 1,50	M 30 x 1,50	M35 x 1,50	M40 x 1,50
N (k6)	15	17	20	25	30	35	40
O	20	24	26	32	37	42	47
P Maxi	24,7	26,5	32,5	37,1	44,2	50,8	56,5
Q	24	30	30	35	42	42	47
R (k6)	20	25	25	30	35	35	40
S	3,5	4	4	4	5	6	8
T	38	54,5	60	79	91	113	148
U	19	23,9	23,9	28,6	33	33	37,5
U1	1,3	1,3	1,3	1,6	1,6	1,6	1,85
V (h11)	20	25	25	30	35	35	40
W	5	5	5	6	6	6	6
X	35	45	55	63	75	90	110
Y	4	6	8	10	10	10	10
Z	8	12	15	16	17	17	18

BACKLASH ADJUSTMENT DEVICE FOR *DYNASET*

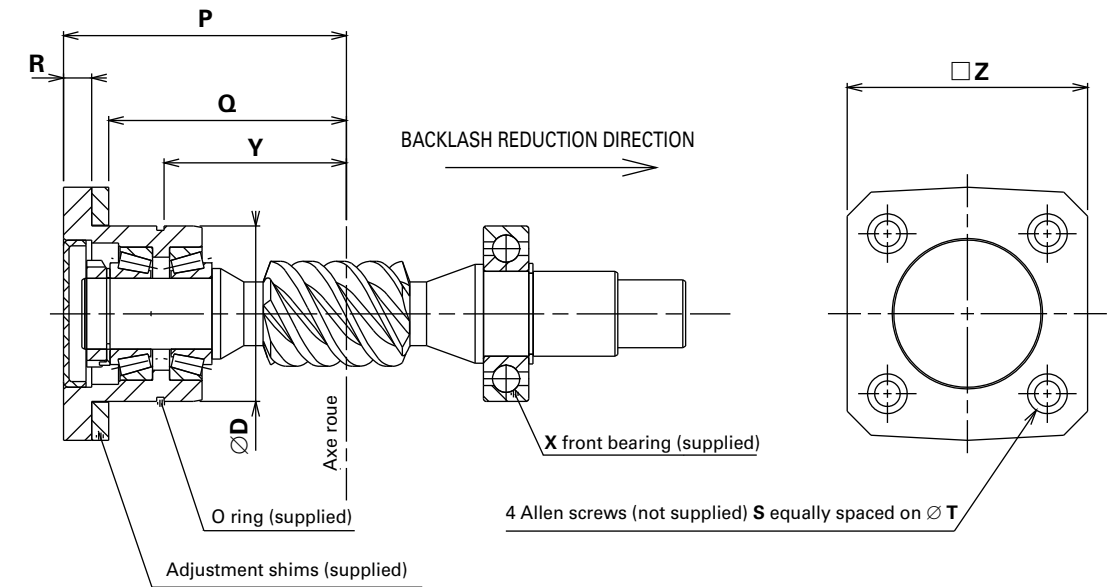

<i>DYNASET</i>	35	45	55	63	75	90	110
D	42	47	52	62	72	72	80
Y Maxi	43,5	54	58	65	84	94	110
Y Mini	38,5	49	53	59	78	88	104
P Maxi	69	83	91	100	121	131,5	150
P Mini	64	78	86	94	115	125,5	144
Q	55	67,5	75	84	104	114,5	132
R	9	10,5	10	10	11	11	12
S	M6	M6	M8	M8	M10	M10	M10
T	55	65	66	80	90	100	100
Z	58	75	75	95	95	115	115
X	16004	6005	6205	6206	6207	6207	6208

The backlash adjustment device is delivered mounted and preset.

Bearings are factory preloaded.

Backlash adjustment is operated with shims located between the housing and the bearing bush.

HOW TO ORDER

Use following codification to order your *DYNASET*.



Visit our website : www.girard-transmissions.com to :
Discover our international sales network
Download Autocad drawings

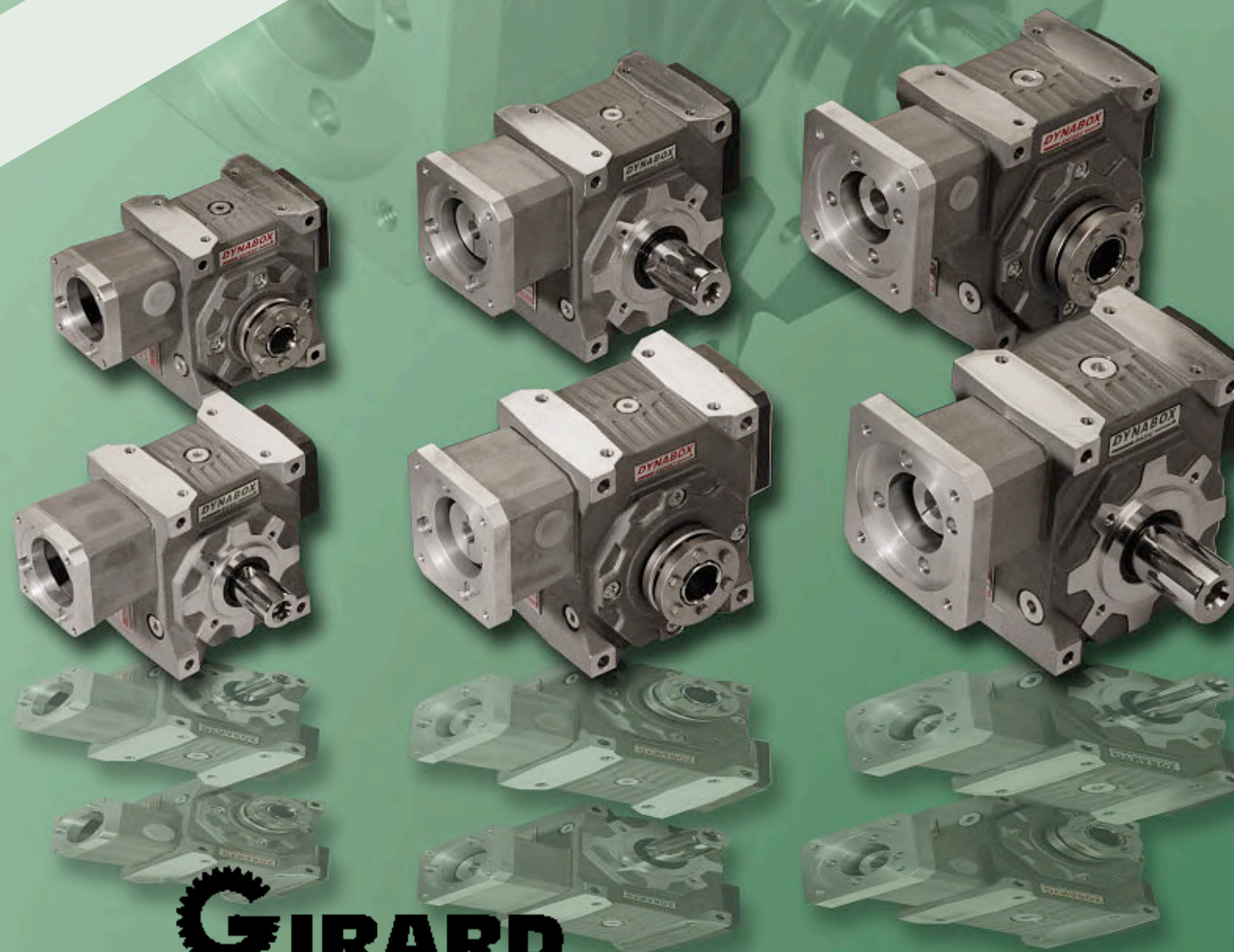

GIRARD
TRANSMISSIONS
PRECISION GEARHEADS

B.P. 208 - Zone Induspal - LONS 64142 BILLÈRE CEDEX FRANCE - Tél. (33) 05 59 40 03 03 - Fax (33) 05 59 32 11 45
Web : www.girard-transmissions.com E-mail : sales@girard-transmissions.com

G05-06-0058 - IMPRIMERIE MODERNE 05 59 132 132