

Balancing with BMT150M on grinding machines

The many thousands of times BMT100M successful in its modern continuation, even faster and easier to use!

What do you improve by balancing?

- Surface and geometry
- Life of the spindle bearings
- Use of grinding wheels (Corundum and CBN)
- Productivity

What do you need?

- One balancing controller BMT150M (usable for any number of machines)
- One vibration sensor and one speed sensor per machine
- One 360° scale ring per flange size



How do you proceed?

- After set up (once per machine), push the weight segments of your grinding wheel flange on the angular positions shown at the display.
- Ready balanced in only 1 minute!

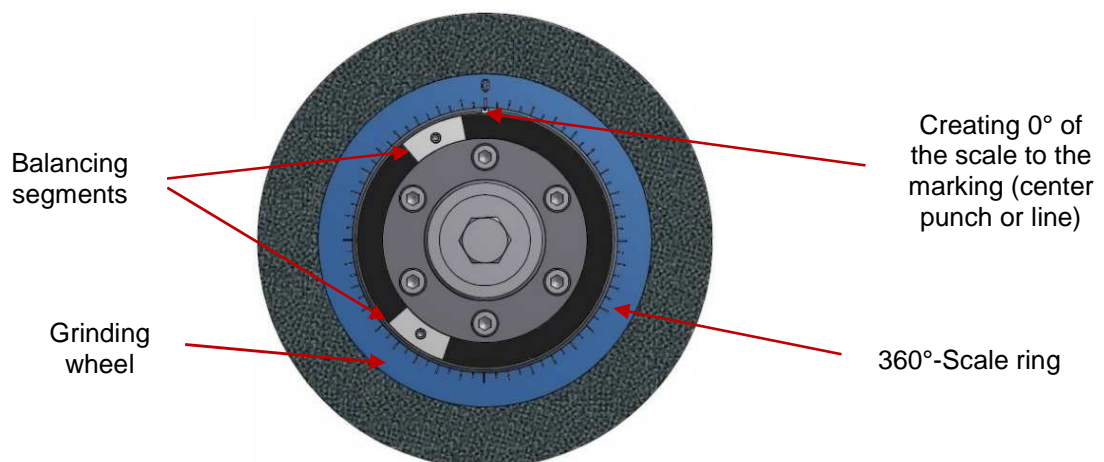

If no flange with balancing segments available, please ask for MPM balancing rings.

Economy

- Ready to use and easy to operate by any user.
- By using several machines and the significant improvement in results, your amortization is possible in a few weeks

Pleasantly simple operation - high efficiency – favourable price